

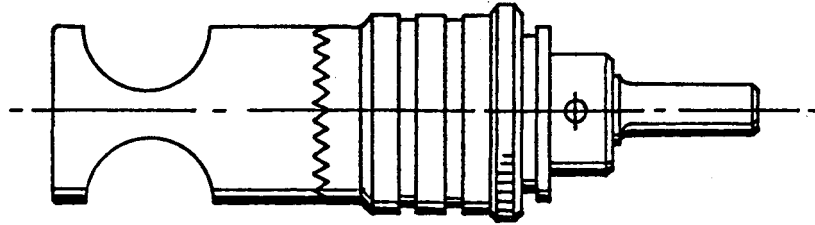

STANDARD SERIES MICRO STOP COUNTERSINK UNITS

- 1/4-28 THREADED SHAFT
- .001 INCREMENT DEPTH ADJUSTMENT
- POSITIVE ADJUSTMENT LOCK
- 9/32 SHAFT TRAVEL
- 1/4 DIA. CHUCKING SHANK



NO. 2196 - STANDARD TYPE SKIRT  
5/8 CUTTER CAPACITY  
RATED AT 3000 R.P.M.

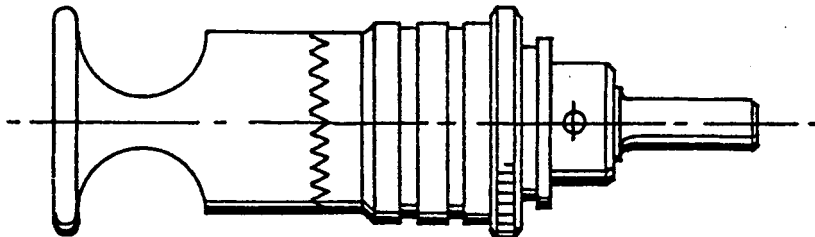

NO. 2197 - FLANGE TYPE SKIRT  
5/8 CUTTER CAPACITY  
RATED AT 3000 R.P.M.

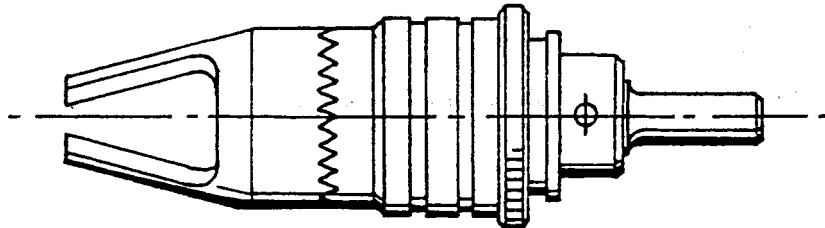

NO. 2198 - TAPERED TYPE SKIRT  
5/16 CUTTER CAPACITY  
RATED AT 3000 R.P.M.

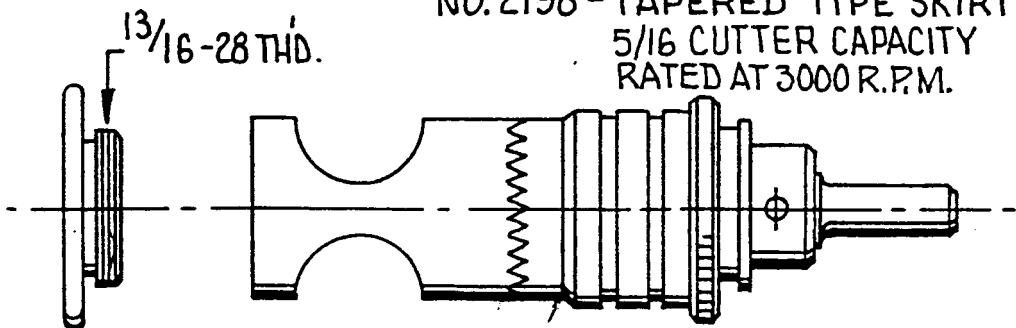

13/16-28 THD.

NO. 2199 - THREADED SKIRT WITH FOOTPIECE  
9/16 CUTTER CAPACITY  
RATED AT 3000 R.P.M.

NO. 1025 NYLON FOOTPIECE

NO. 1026 POLISHED STEEL FOOTPIECE





# MAGNAVON INDUSTRIES

## STANDARD SERIES MICRO STOP COUNTERSINK UNITS

- 1/4-28 THREADED SHAFT
- .001 INCREMENT DEPTH ADJUSTMENT
- POSITIVE ADJUSTMENT LOCK
- 9/32 SHAFT TRAVEL
- 1/4 DIA. CHUCKING SHANK

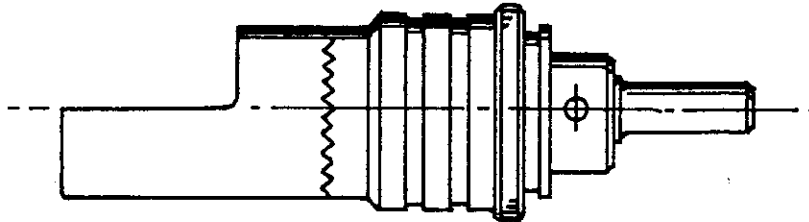

NO. 1216 - CUTAWAY TYPE SKIRT  
5/8 CUTTER CAPACITY  
RATED AT 3000 R.P.M.

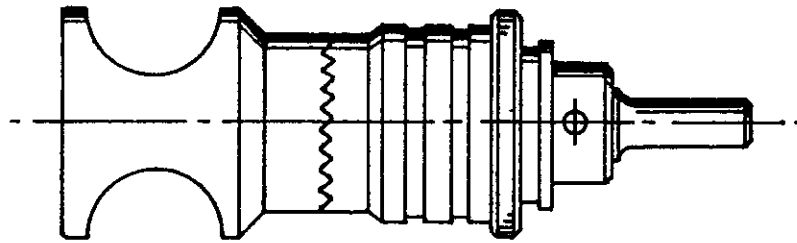

NO. 1218 - BELL TYPE SKIRT  
3/4 CUTTER CAPACITY  
RATED AT 3000 R.P.M.

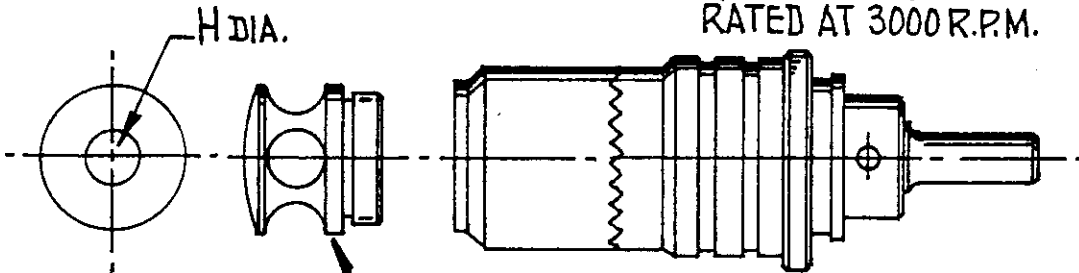

NO. 2216 - SKIN PROTECTOR TYPE  
FOOT PIECE  
RATED AT 3000 R.P.M.

FOOT PIECE			
PART NO.	H DIA.	PART NO.	H DIA.
2215-5	.189	2215-30	.296
↑ -10	.202	↑ -35	.308
-15	.235	-37	.310
-20	.253	-40	.338
-21	.268	-45	.363
↓ -22	.282	↓ -50	.393
2215-25	.285	2215-55	.400





MAGNAVON INDUSTRIES

STANDARD SERIES

MICRO STOP COUNTERSINK UNIT  
NO.1854

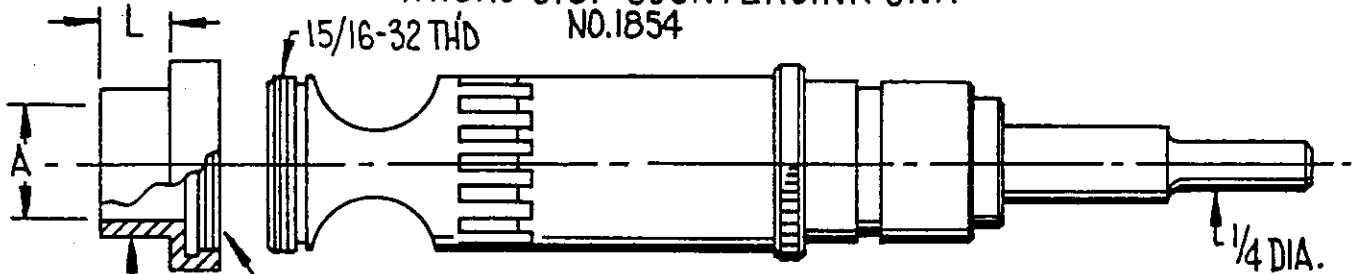

EXAMPLE TO ORDER INSERT :

NO.1201-373-498-.250

— BASIC NO. — "A" DIA — "B" DIA. — "L" LENGTH

- 1" SHAFT TRAVEL
- 1/4-28 THREADED SHAFT
- .001 INCREMENT DEPTH ADJUSTMENT
- POSITIVE ADJUSTMENT LOCK
- RATED AT 3000 R.P.M.

NO SCRATCH FOOTPLATES

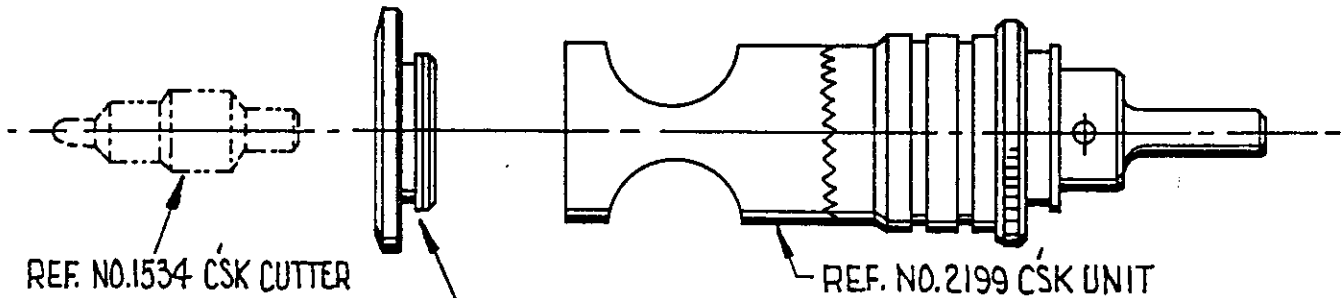

FOOT PLATE	
PART NO.	A
1538-36	.177
1538-37	.209
1538-38	.281
1538-39	.328
1538-40	.422
1538-41	.500

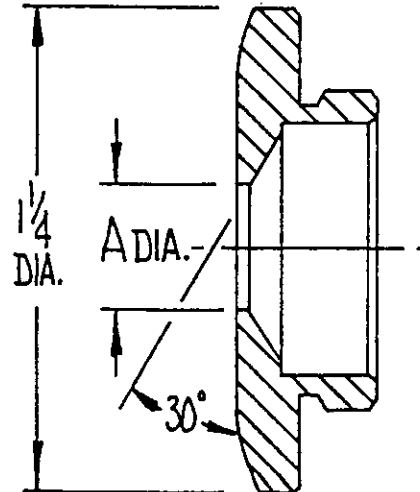



MAGNAVON INDUSTRIES

**STANDARD SERIES** MICRO STOP COUNTERSINK UNITS

ALL THREE UNITS HAVE: 1/4-28 THREADED SHAFT — 1/4" CHUCKING SHANK — .001 INC. DEPTH ADJUSTMENT

3/4-20 THD

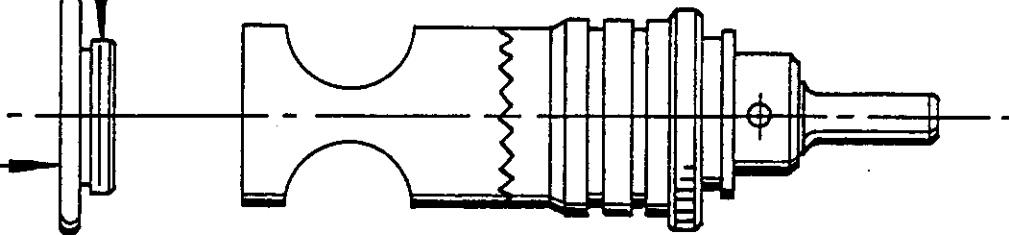

NO.2373 HAS THREADED SKIRT WITH FOOTPIECE

NO.2379 NYLON FOOT PIECE

NO.2380 POLISHED STEEL FOOTPIECE

NO.2381 MICARTA FOOT PIECE

• 9/16 CUTTER CAPACITY

• 9/32 SHAFT TRAVEL

• RATED AT 3000 R.P.M.

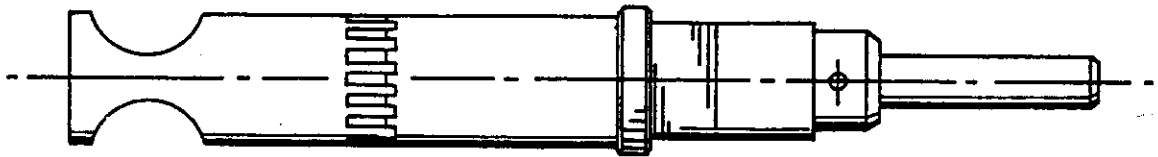

NO.1166 LONG TRAVEL MIDGET UNIT

• 7/16 CUTTER CAPACITY

• 11/16 OUTSIDE DIA.

• 3/4 SHAFT TRAVEL

• RATED AT 3000 R.P.M.

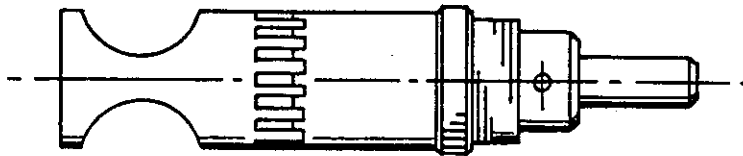

NO.2334 MIDGET UNIT

• 7/16 CUTTER CAPACITY

• 11/16 OUTSIDE DIA.

• 9/32 SHAFT TRAVEL

• RATED AT 3000 R.P.M.





MICRO-STOP COUNTERSINK UNIT-EXTENDED FOOT PIECE TYPE

**STANDARD SERIES**

- o .001 INCREMENT DEPTH ADJUSTMENT
- o POSITIVE ADJUSTMENT LOCK
- o RATED AT 3000 R.P.M.

PART NO.	A	B	SHAFT THREAD	L
2616-27-37	.275	.375	10-32	3/8
-32-42	.325	.425	1/4-28	
-40-50	.400	.500	1/4-28	
-65-75	.656	.750	1/4-28	
2995-27-37	.275	.375	10-32	1/4
-32-42	.325	.425	1/4-28	
-40-50	.400	.500	1/4-28	
-65-75	.656	.750	1/4-28	
2220-27-37	.275	.375	10-32	2 3/4
-32-42	.325	.425	1/4-28	
-40-50	.400	.500	1/4-28	
-65-75	.656	.750	1/4-28	
2991-27-37	.275	.375	10-32	4
-32-42	.325	.425	1/4-28	
-40-50	.400	.500	1/4-28	
-65-75	.656	.750	1/4-28	
2474-27-37	.275	.375	10-32	5
-32-42	.325	.425	1/4-28	
-40-50	.400	.500	1/4-28	
-65-75	.656	.750	1/4-28	

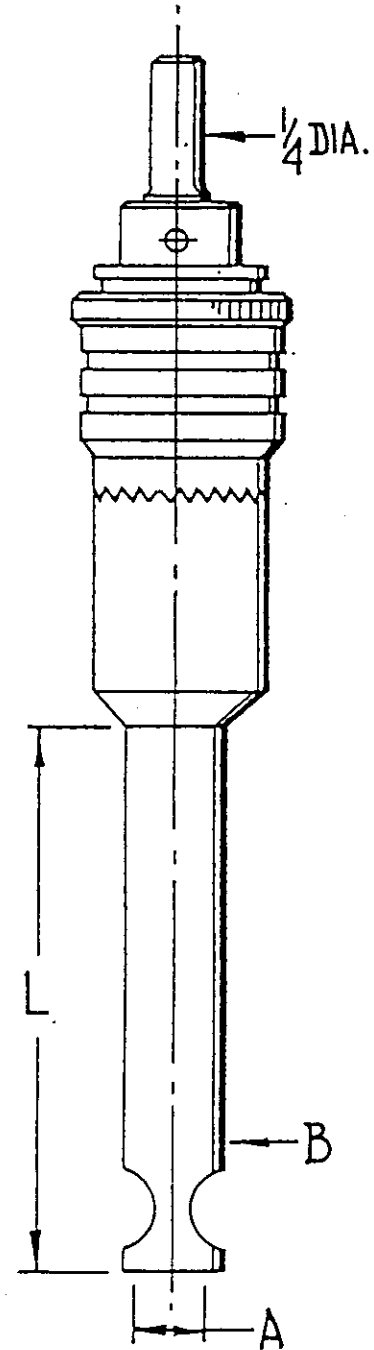



MAGNAVON INDUSTRIES

STANDARD SERIES MICRO-STOP COUNTERSINK UNIT

NO. 1456

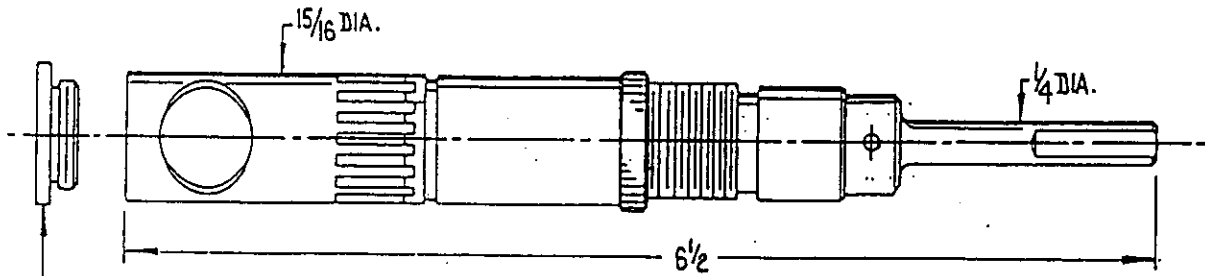

FOOT PIECES

NO.1211  
 NO.1025  
 NO.1026  
 NO.1842

- 3/4" SHAFT TRAVEL
- .001 INCREMENT DEPTH ADJUSTMENT
- POSITIVE ADJUSTMENT LOCK
- 1/4-28 THREADED SHAFT
- RATED AT 3000 R.P.M.

STANDARD SERIES MICRO-STOP COUNTERSINK UNIT

NO.2590

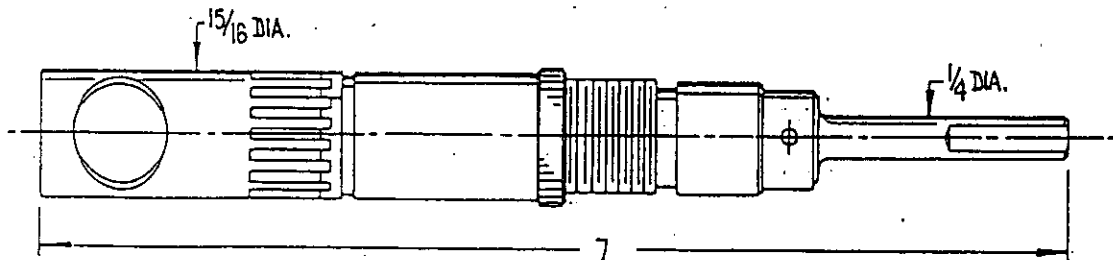

- 1" SHAFT TRAVEL
- .001 INCREMENT DEPTH ADJUSTMENT
- POSITIVE ADJUSTMENT LOCK
- 1/4-28 THREADED SHAFT
- RATED AT 3000 R.P.M.





MAGNAVON INDUSTRIES

**STANDARD SERIES** MICRO-STOP COUNTERSINK UNIT

NO.1116

- 9/16 SHAFT TRAVEL
- .001 INCREMENT DEPTH ADJUSTMENT
- POSITIVE ADJUSTMENT LOCK
- 1/4-28 SHAFT THREAD
- DESIGNED TO USE DRILL PILOT TYPE COUNTERSINK CUTTERS
- RATED AT 3000 R.P.M.

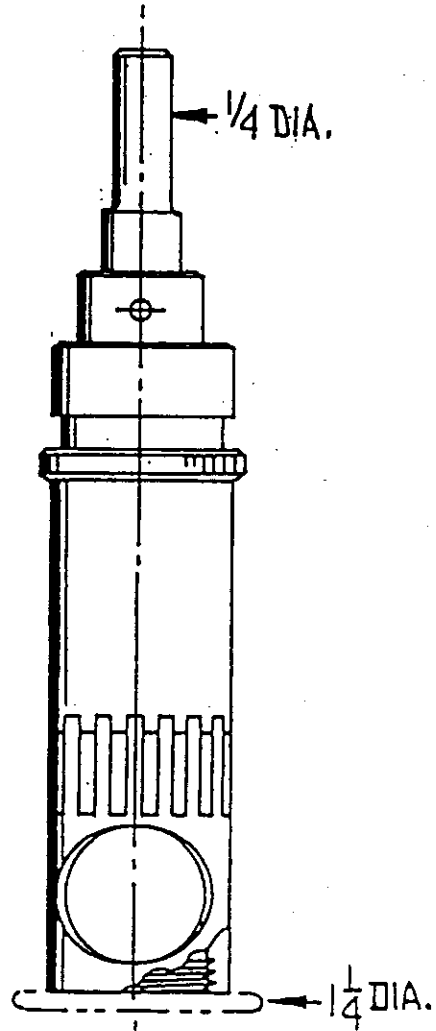

EXAMPLE TO ORDER NO.1211 INSERTS :

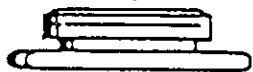
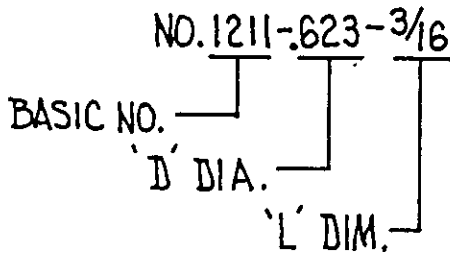

NO.1025  
NYLON INSERT

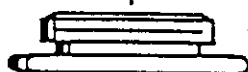

NO.1026  
NO-MAR STEEL INSERT

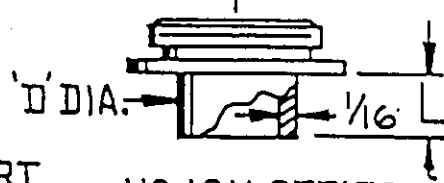

NO.1211 SERIES  
INSERTS





MAGNAVON INDUSTRIES

STANDARD SERIES MICRO-STOP COUNTERSINK UNIT

NO. 1210 UNIT

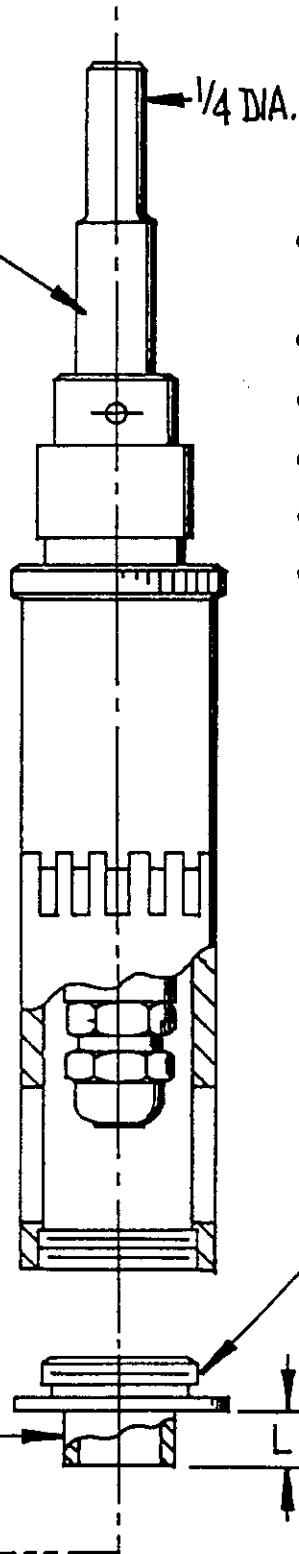

- DESIGNED TO USE DRILL AND COUNTERSINK CUTTERS WITH 1/4" DIA. SHANK
- SPINDLE HAS 1/4" SIZE COLLET
- 3/4" SHAFT TRAVEL
- .001 INCREMENT DEPTH ADJUSTMENT
- POSITIVE ADJUSTMENT LOCK
- USE WITH STANDARD DRILL TEMPLATES
- RATED AT 3000 R.P.M.

NO. 1211 SERIES INSERTS

PART NO.	D	L
1211 - 373 - 5/32	.373	5/32
1211 - 498 - 3/16	.498	3/16
1211 - 623 - 1/4	.623	1/4
1211 - 373 - 1/4	.373	1/4
1211 - 498 - 5/16	.498	5/16
1211 - 623 - 3/8	.623	3/8







MAGNAVON INDUSTRIES

MICRO STOP COUNTERSINK UNIT **HEAVY DUTY PRECISION SERIES**

NO.2142

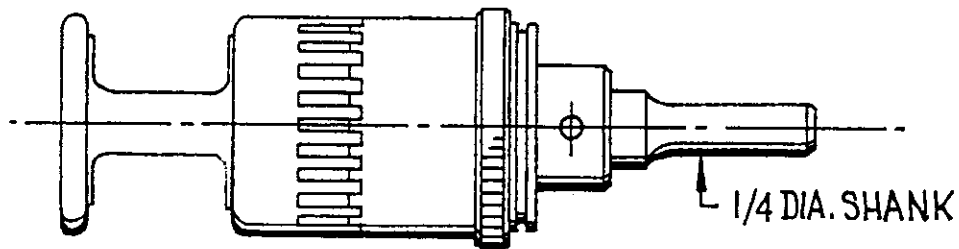

- FULL FLANGE SKIRT
- FULL BALL BEARING CONSTRUCTION
- OPERATES UP TO 10000 R.P.M.
- 1/4-28 THREADED SHAFT
- .001 INCREMENT DEPTH ADJUSTMENT
- 9/32 SHAFT TRAVEL
- 5/8 CUTTER CAPACITY

MICRO STOP COUNTERSINK UNIT **HEAVY DUTY PRECISION SERIES**

NO.2143

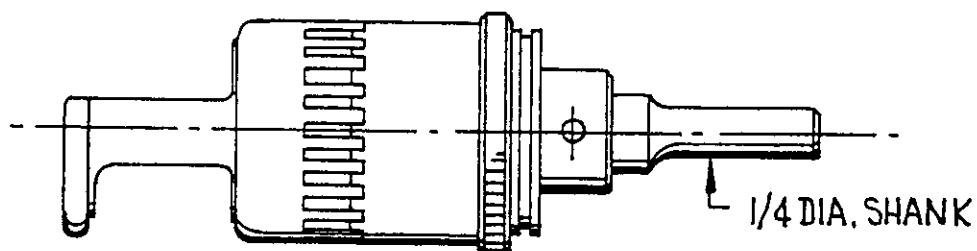

- CUT AWAY FLANGE SKIRT
- FULL BALL BEARING CONSTRUCTION
- OPERATES UP TO 10000 R.P.M.
- 1/4-28 THREADED SHAFT
- .001 INCREMENT DEPTH ADJUSTMENT
- 9/32 SHAFT TRAVEL
- 5/8 DIA. CUTTER CAPACITY





MICRO STOP COUNTERSINK UNIT **HEAVY DUTY PRECISION SERIES**

NO.2274

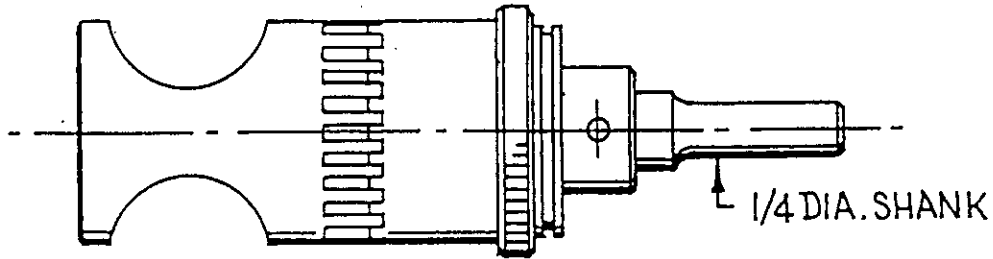

- STRAIGHT TYPE SKIRT
- FULL BALL BEARING CONSTRUCTION
- OPERATES UP TO 10000 R.P.M.
- 1/4-28 THREADED SHAFT
- .001 INCREMENT DEPTH ADJUSTMENT
- 9/32 SHAFT TRAVEL
- 3/4 DIA. CUTTER CAPACITY

MICRO STOP COUNTERSINK UNIT **HEAVY DUTY PRECISION SERIES**

NO.2824

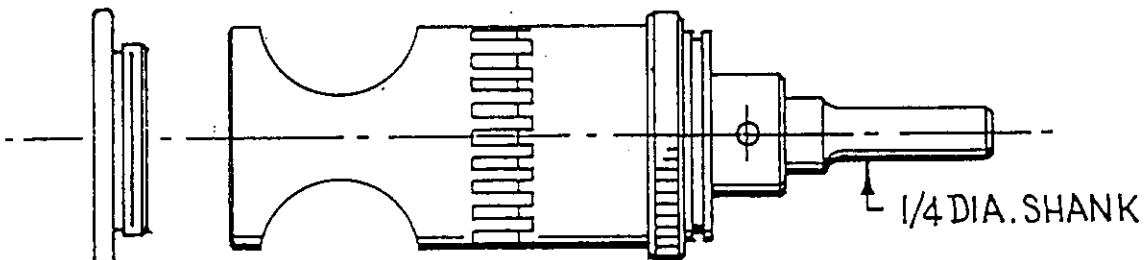

**FOOT PIECES**

- NO.2825 NYLON
- NO.2826 MICARTA
- NO.2827 POLISHED STEEL

- STRAIGHT TYPE SKIRT THREADED FOR FOOT PIECES
- FULL BALL BEARING CONSTRUCTION
- OPERATES UP TO 10000 R.P.M.
- 1/4-28 THREADED SHAFT
- .001 INCREMENT DEPTH ADJUSTMENT
- 9/32 SHAFT TRAVEL
- 3/4 DIA. CUTTER CAPACITY





MAGNAVON INDUSTRIES

MICRO STOP COUNTERSINK UNITS HEAVY DUTY PRECISION SERIES  
DESIGNED TO COUNTERSINK FOR AN426 AND BRILES FAST RIVETS

NO. 3342

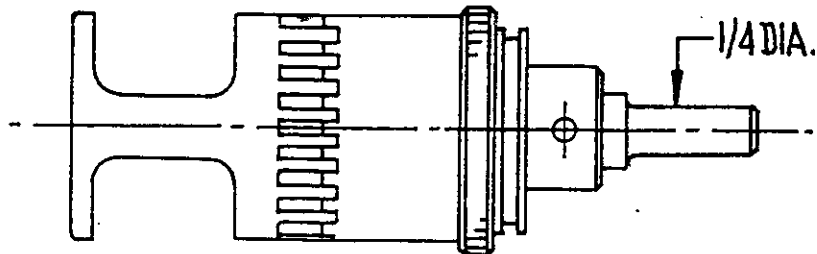

- STRAIGHT TYPE SKIRT
- FULL BALL BEARING CONSTRUCTION
- POSITIVE HARD STOP
- OPERATES UP TO 10,000 R.P.M.
- 1/4-28 THREADED SHAFT
- ADJUSTABLE IN .001 INCREMENTS
- 1/4 INCH SHAFT TRAVEL
- 5/8 CUTTER CAPACITY

NO. 3343

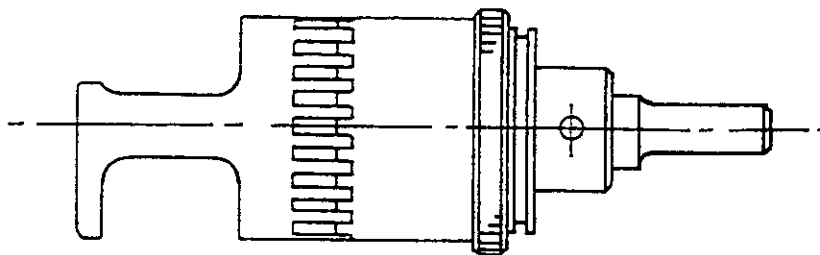

- CUT AWAY TYPE SKIRT
- NOTE:  
ALL OTHER FEATURES ARE IDENTICAL  
TO MICRO STOP NO. 3342





MAGNAVON INDUSTRIES

MICRO STOP COUNTERSINK UNIT **HEAVY DUTY SERIES**  
NO. 2192

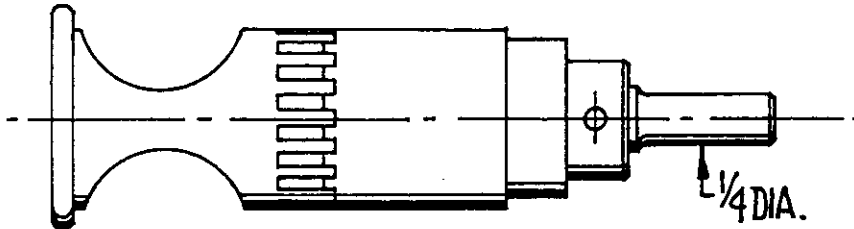

- FULL FLANGE SKIRT
- FULL BEARING TYPE
- OPERATES UP TO 6000 R.P.M.
- 1/4-28 THREADED SHAFT
- .001 INCREMENT DEPTH ADJUSTMENT
- 9/32 SHAFT TRAVEL
- 5/8 DIA. CUTTER CAPACITY

MICRO STOP COUNTERSINK UNIT **HEAVY DUTY SERIES**  
NO. 2194

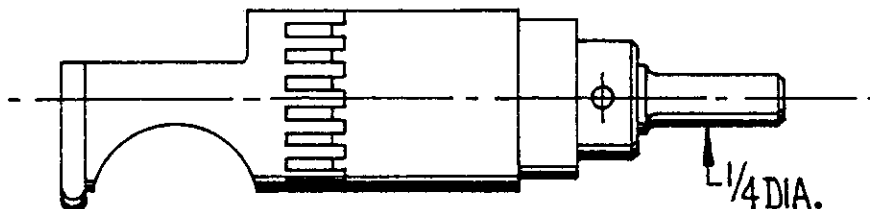

- CUT AWAY FLANGE SKIRT
- FULL BEARING TYPE
- OPERATES UP TO 6000 R.P.M.
- 1/4-28 THREADED SHAFT
- .001 INCREMENT DEPTH ADJUSTMENT
- 9/32 SHAFT TRAVEL
- 5/8 DIA. CUTTER CAPACITY





MAGNAVON INDUSTRIES

**HEAVY DUTY SERIES** MICRO STOP COUNTERSINK UNITS

- 1/4-28 THREADED SHAFT
- .001 INCREMENT DEPTH ADJUSTMENT
- POSITIVE ADJUSTMENT LOCK
- 9/32 SHAFT TRAVEL
- 1/4 DIA. CHUCKING SHANK

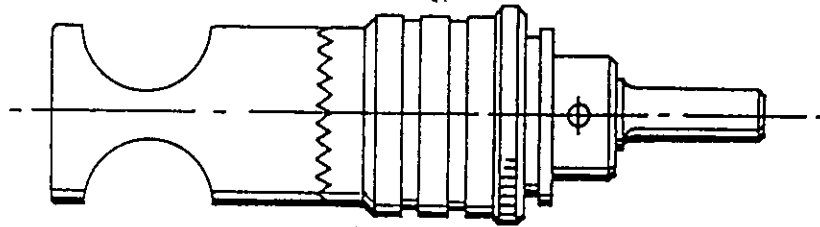

NO.2844 - STANDARD TYPE SKIRT  
5/8 CUTTER CAPACITY  
RATED AT 3000 R.P.M.

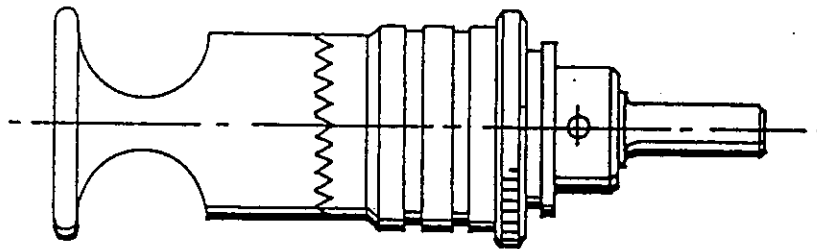

NO.2845 - FLANGE TYPE SKIRT  
5/8 CUTTER CAPACITY  
RATED AT 3000 R.P.M.

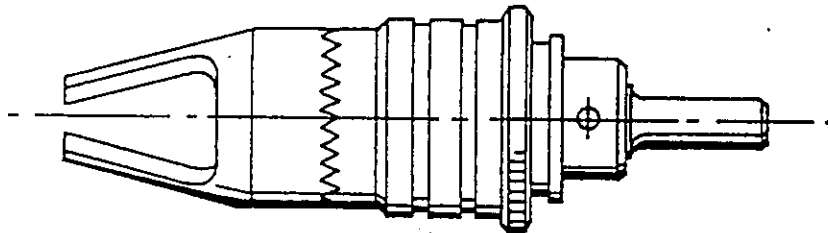

NO.2846 - TAPERED TYPE SKIRT  
5/16 CUTTER CAPACITY  
RATED AT 3000 R.P.M.

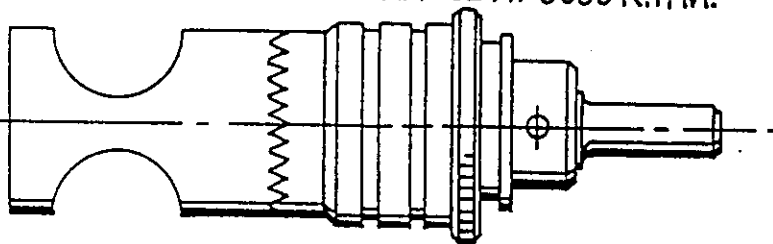
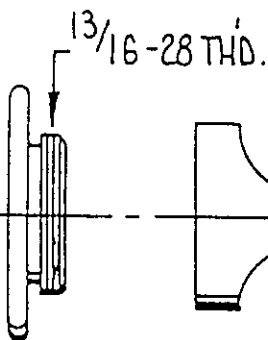

NO.2847 - THREADED SKIRT WITH FOOTPIECE  
NO.1025 NYLON FOOTPIECE 9/16 CUTTER CAPACITY  
NO.1026 POLISHED STEEL FOOTPIECE RATED AT 3000 R.P.M.





**HEAVY DUTY SERIES** MICRO-STOP COUNTERSINK UNITS

- 1/4-28 THREADED SHAFT
- .001 INCREMENT DEPTH ADJUSTMENT
- POSITIVE ADJUSTMENT LOCK
- 9/32 SHAFT TRAVEL
- 1/4 DIA. CHUCKING SHANK

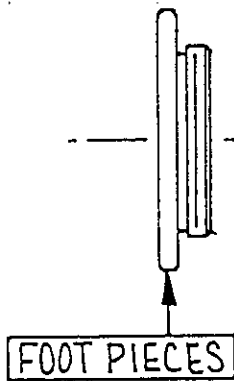

- FOOT PIECES**
- NO.2825 NYLON
  - NO.2826 MICARTA
  - NO.2827 POLISHED STEEL

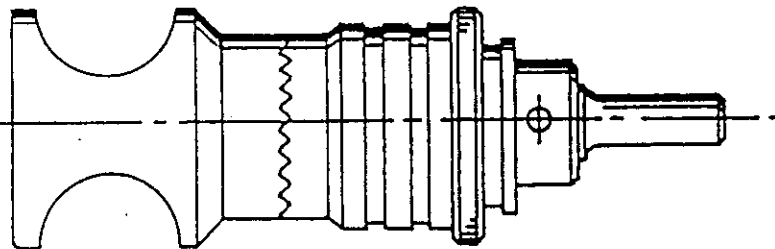

NO.2849 - BELL TYPE SKIRT (THREADED)  
3/4 CUTTER CAPACITY  
RATED AT 3000 R.P.M.

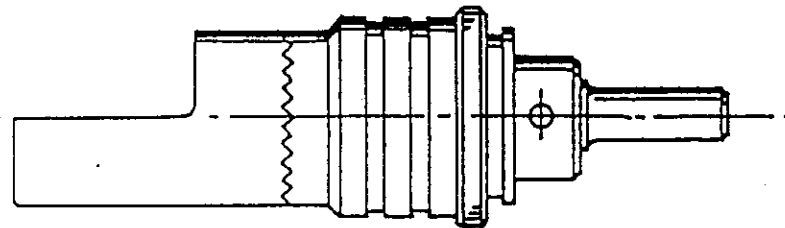

NO.2848 - CUTAWAY TYPE SKIRT  
5/8 CUTTER CAPACITY  
RATED AT 3000 R.P.M.

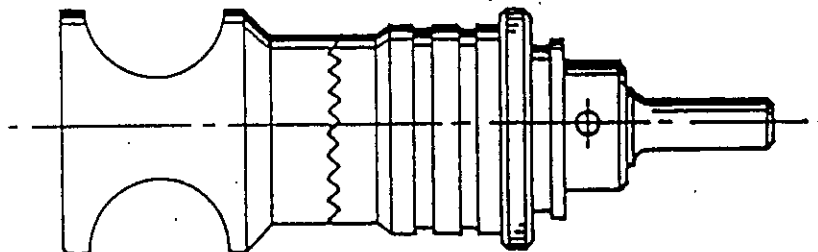

NO.2850 - BELL TYPE SKIRT  
3/4 CUTTER CAPACITY  
RATED AT 3000 R.P.M.



# MAGNAVON INDUSTRIES

## HEAVY DUTY SERIES

## MICRO STOP COUNTERSINK UNITS

- 1/4-28 THREADED SHAFT
- .001 INCREMENT DEPTH ADJUSTMENT
- POSITIVE ADJUSTMENT LOCK
- 9/32 SHAFT TRAVEL
- 1/4 DIA. CHUCKING SHANK

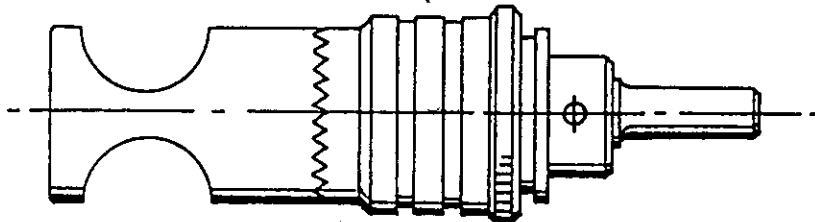

NO.2560 - STANDARD TYPE SKIRT  
5/8 CUTTER CAPACITY  
RATED AT 6000 R.P.M.

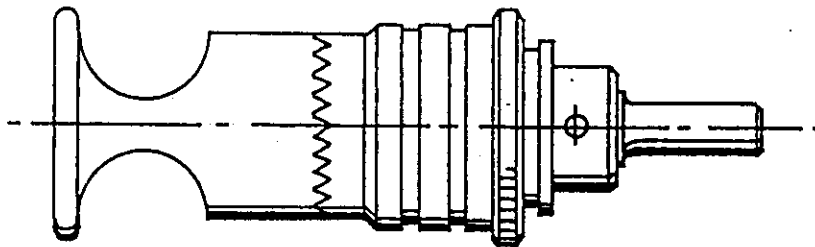

NO.2774 - FLANGE TYPE SKIRT  
5/8 CUTTER CAPACITY  
RATED AT 6000 R.P.M.

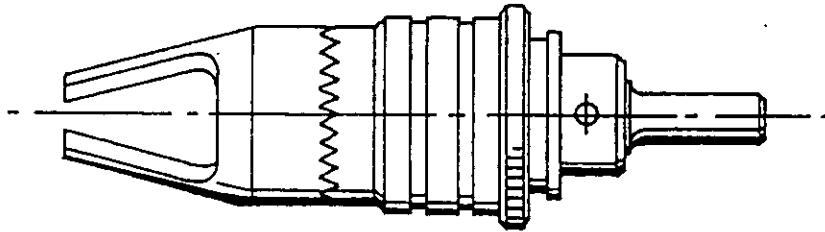

NO.2791 - TAPERED TYPE SKIRT  
5/16 CUTTER CAPACITY  
RATED AT 6000 R.P.M.

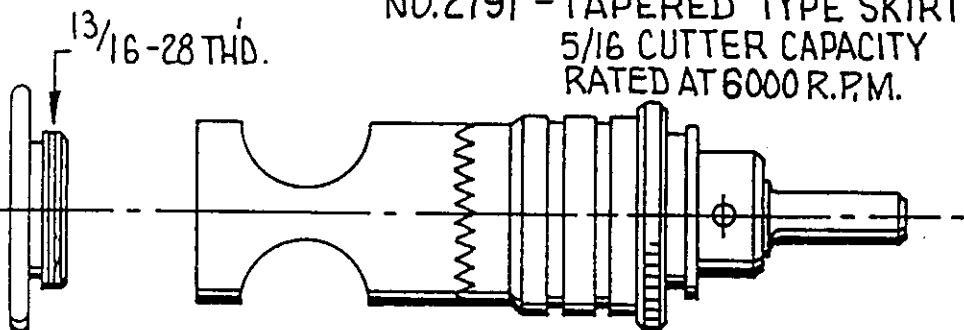

NO.2792 - THREADED SKIRT WITH FOOTPIECE  
9/16 CUTTER CAPACITY  
RATED AT 6000 R.P.M.

NO.1025 NYLON FOOTPIECE

NO.1026 POLISHED STEEL FOOTPIECE





**HEAVY DUTY SERIES** MICRO STOP COUNTERSINK UNITS

- 1/4-28 THREADED SHAFT
- .001 INCREMENT DEPTH ADJUSTMENT
- POSITIVE ADJUSTMENT LOCK
- 9/32 SHAFT TRAVEL
- 1/4 DIA. CHUCKING SHANK

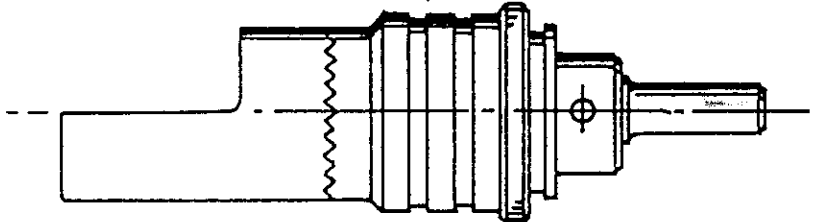

NO. 2748 - CUTAWAY TYPE SKIRT  
5/8 CUTTER CAPACITY  
RATED AT 6000 R.P.M.

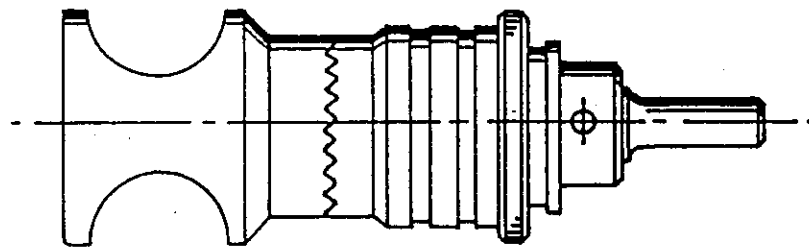

NO. 2747 - BELL TYPE SKIRT  
3/4 CUTTER CAPACITY  
RATED AT 6000 R.P.M.

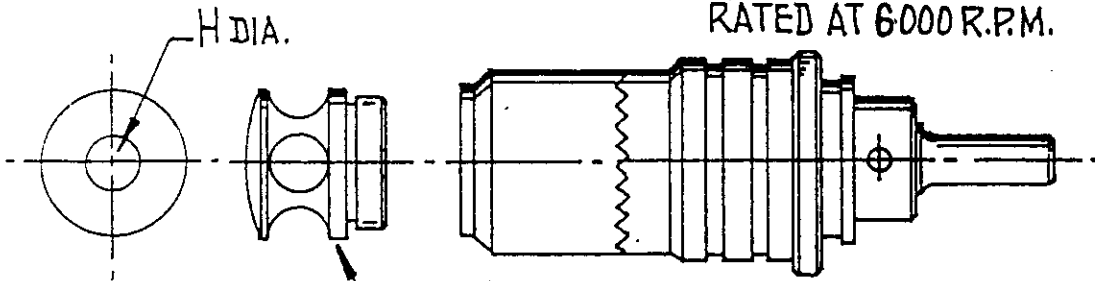

NO. 2399 - SKIN PROTECTOR TYPE  
FOOT PIECE  
RATED AT 6000 R.P.M.

FOOT PIECE			
PART NO.	H DIA.	PART NO.	H DIA.
2215-5	.189	2215-30	.296
▲ -10	.202	▲ -35	.308
▲ -15	.235	▲ -37	.310
▲ -20	.253	▲ -40	.338
▲ -21	.268	▲ -45	.363
▼ -22	.282	▼ -50	.393
2215-25	.285	2215-55	.400





MAGNAVON INDUSTRIES

HEAVY DUTY SERIES

MICRO STOP COUNTERSINK UNITS

- .001 INCREMENT DEPTH ADJUSTMENT
- POSITIVE ADJUSTMENT LOCK
- 9/32 SHAFT TRAVEL
- 1/4 DIA. CHUCKING SHANK
- USES CUTTERS WITH 00 STUB TAPER SHANKS
- RATED AT 3000 R.P.M.

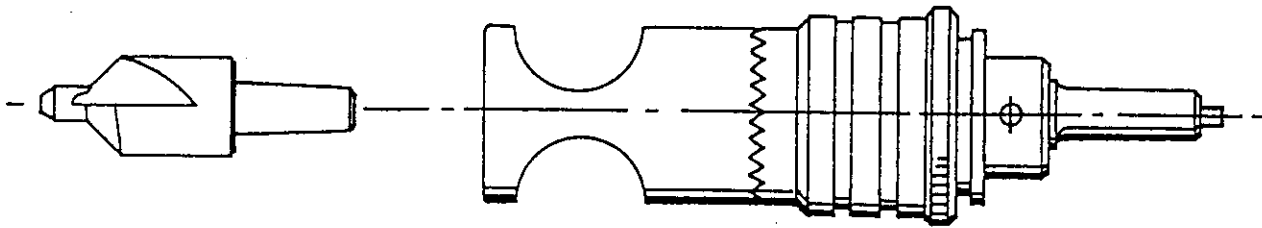

NO.2800 - STANDARD TYPE SKIRT  
5/8 CUTTER CAPACITY

- .001 INCREMENT DEPTH ADJUSTMENT
- POSITIVE ADJUSTMENT LOCK
- 9/32 SHAFT TRAVEL
- 1/4 DIA. CHUCKING SHANK
- USES CUTTERS WITH COMBINATION 15° AND  
1/4-28 THREADED SHANK
- RATED AT 3000 R.P.M.

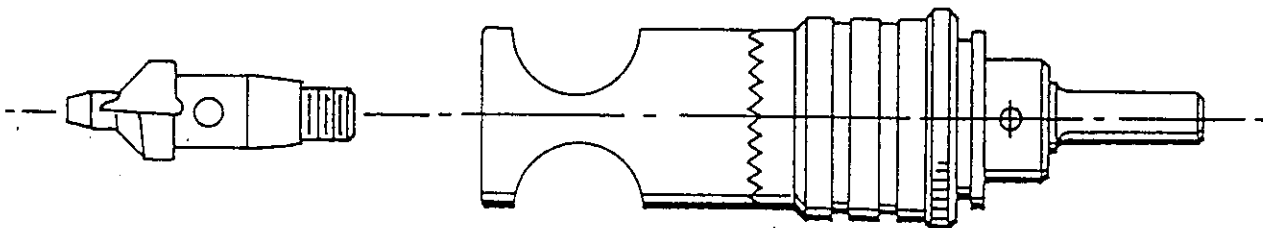

NO.3027 - STANDARD TYPE SKIRT  
5/8 CUTTER CAPACITY





LIGHT DUTY SERIES MICRO-STOP COUNTERSINK UNITS

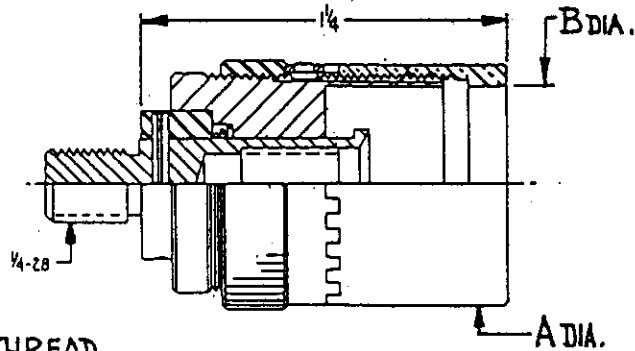

- 3/32 SHAFT TRAVEL
- 1/4-28 FEMALE SHAFT THREAD
- .001 INCREMENT DEPTH ADJUSTMENT
- POSITIVE ADJUSTMENT LOCK
- RATED AT 3000 R.P.M.

PART NO.	A	B
2714	9/16	25/64
2715	13/16	21/32

LIGHT DUTY SERIES MICRO-STOP COUNTERSINK UNITS

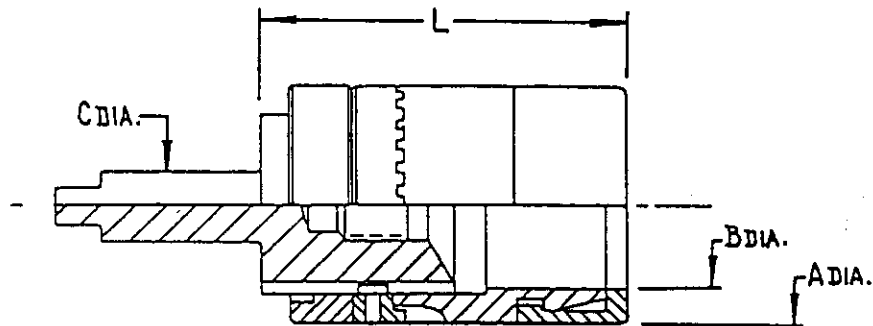

- FREE ROTATING NOSE COLLAR
- .001 INCREMENT DEPTH ADJUSTMENT
- POSITIVE ADJUSTMENT LOCK
- RATED AT 2000 R.P.M.

PART NO.	A	B	C	SPINDLE THREAD	L
2330	13/16	19/32	1/4	1/4-28	1 1/4
2335	13/16	19/32	3/16	1/4-28	1 1/4
2336	7/8	5/8	1/4	3/8-24	1 3/4
2337	1 1/16	13/16	1/4	3/8-24	1 3/4
2338	9/16	11/32	3/16	1/4-28	1 1/4





MAGNAVON INDUSTRIES

HEAVY DUTY PRECISION SERIES MICRO-STOP COUNTERSINK UNITS

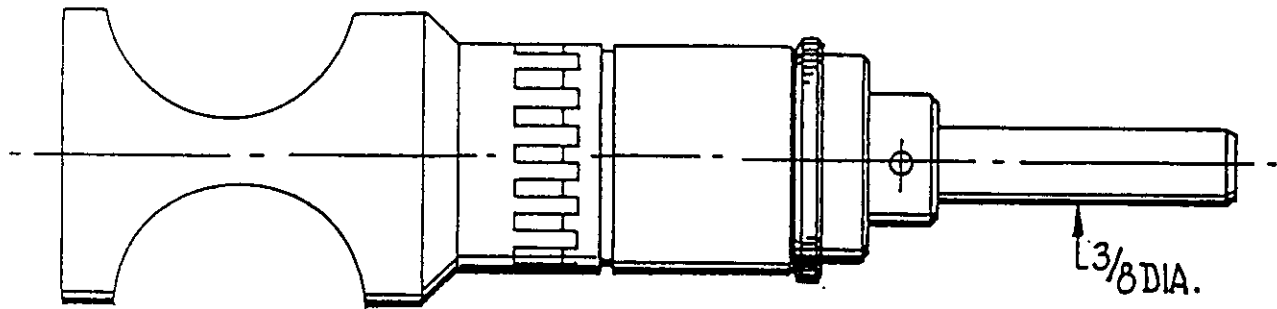

- FULL BALL BEARING CONSTRUCTION
- OPERATES UP TO 10,000 R.P.M.
- .001 INCREMENT DEPTH ADJUSTMENT.
- POSITIVE ADJUSTMENT LOCK

PART NO.	CUTTER CAPACITY	SHAFT THREAD	STROKE
2177	1 1/2	7/16-20	1/2
2190	1 1/4	7/16-20	
2299	1 1/4	3/8-24	
2268	7/8	3/8-24	
2269	1 1/2	3/8-24	
2270	7/8	7/16-20	
2333	1 1/2	5/8-18	
2528	1 7/8	5/8-18	1
2445	1 3/4	5/8-18	
2446	1 1/4	7/16-20	

HEAVY DUTY PRECISION SERIES MICRO-STOP COUNTERSINK UNITS

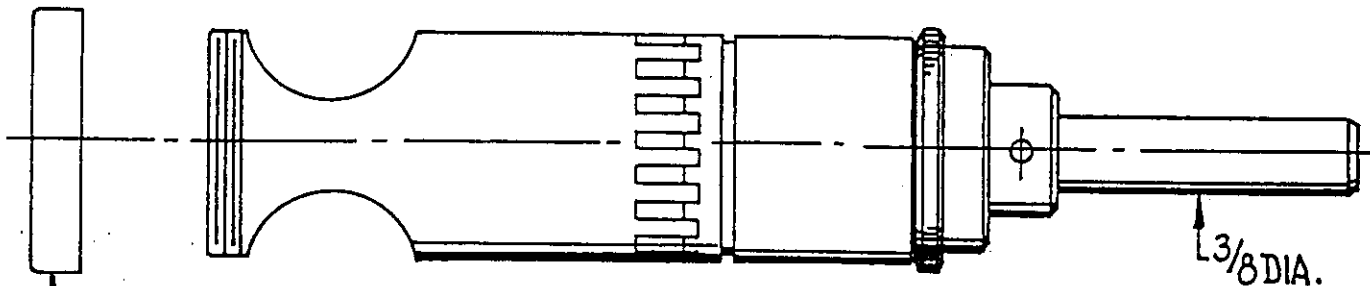

- NO.2447 NYLON FOOT PIECE
- NO.2448 POLISHED STEEL FOOT PIECE

PART NO.	CUTTER CAPACITY	SHAFT THREAD	STROKE
2998	7/8	3/8-24	1/2
2999	7/8	7/16-20	





STANDARD SERIES MICRO-STOP COUNTERSINK UNITS

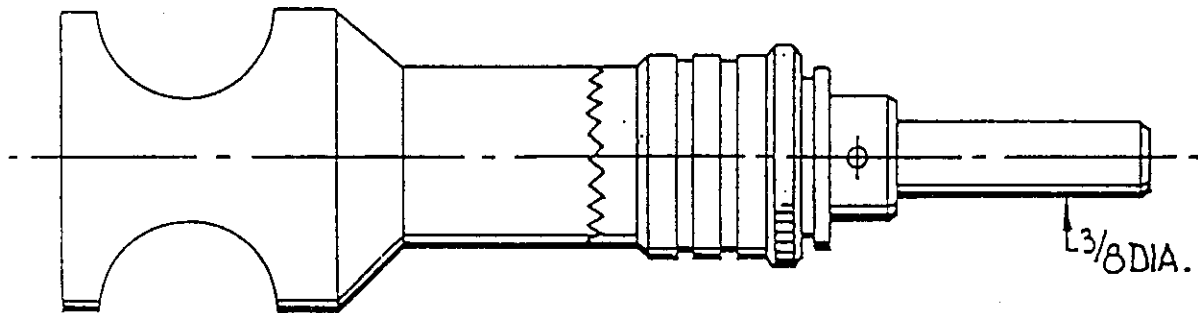

- BRONZE BEARING CONSTRUCTION
- RATED AT 3000 R.P.M.
- .001 INCREMENT DEPTH ADJUSTMENT
- POSITIVE ADJUSTMENT LOCK

PART NO.	CUTTER CAPACITY	SHAFT THREAD	STROKE
2173	1 3/8	3/8-24	1/4
2174	1 3/8	7/16-20	
2188	1 1/4	3/8-24	
2189	7/8	3/8-24	
2191	7/8	7/16-20	
2297	1 1/4	7/16-20	

STANDARD SERIES MICRO-STOP COUNTERSINK UNITS

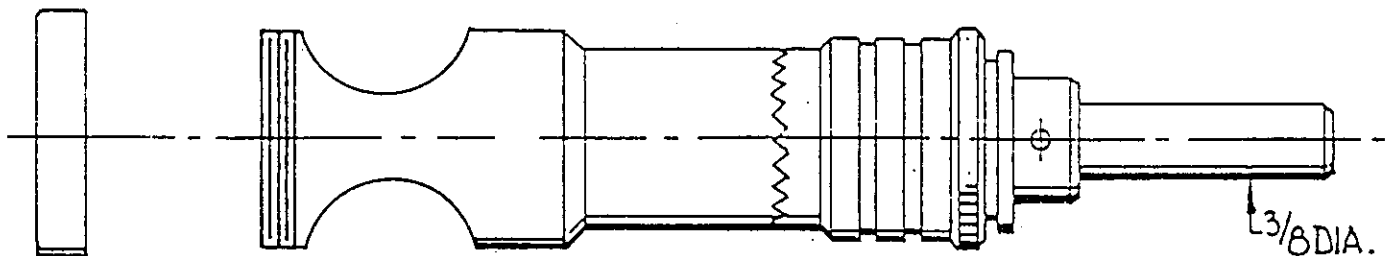

- NO. 2447 NYLON FOOT PIECE
- NO. 2448 POLISHED STEEL FOOT PIECE.

PART NO.	CUTTER CAPACITY	SHAFT THREAD	STROKE
2450	7/8	3/8-24	1/4
3001	7/8	7/16-20	



MAGNAVON INDUSTRIES

STANDARD SERIES

MICRO STOP COUNTERSINK UNIT  
NO.1059

DESIGNED TO ACCOMODATE TAPER-LOK  
CUTTERS NO.TLD2040 AND TLD2024R  
WITH 1/4-28 THREADED SHANKS.

- 1 1/2 SHAFT TRAVEL.
- .001 INCREMENT DEPTH ADJUSTMENT.
- BALL BEARING DEPTH STOP.
- 1/4-28 FEMALE THREADED SHAFT.
- POSITIVE LOCK ADJUSTMENT.
- 5/16 DIA. SHANK WITH THREE FLATS.
- RATED AT 3000 R.P. M.

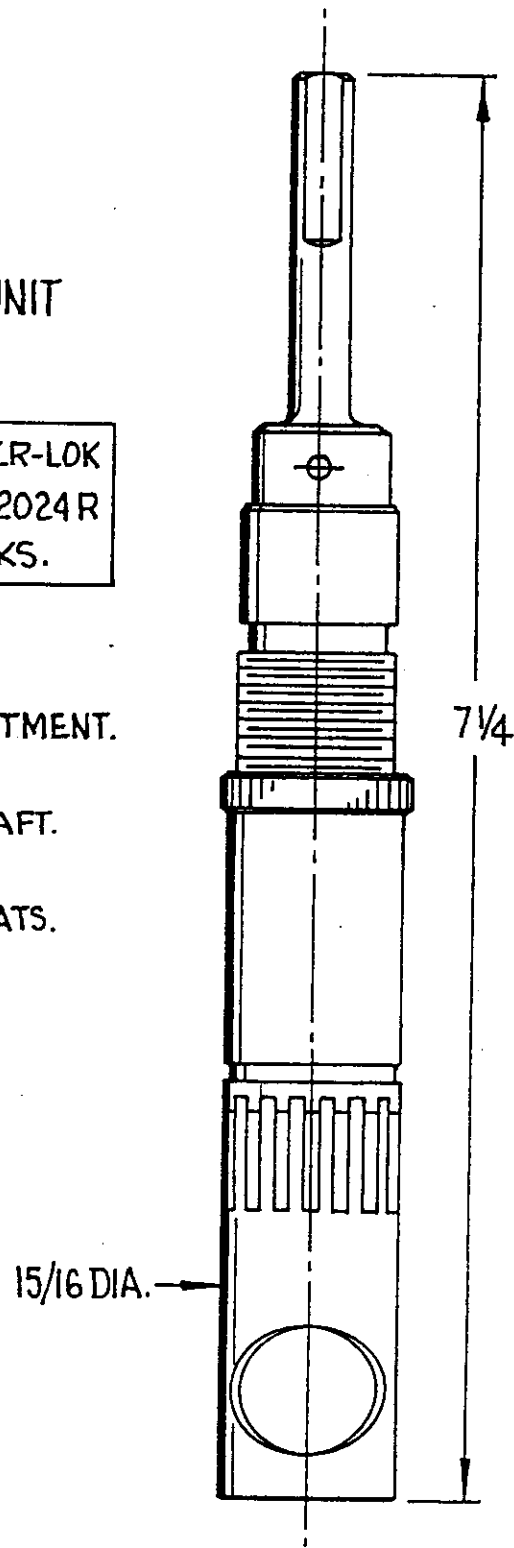



MAGNAVON INDUSTRIES

HEAVY DUTY PRECISION SERIES

MICRO STOP COUNTERSINK UNIT  
NO.2559

DESIGNED TO ACCOMODATE TAPER-LOK  
CUTTERS NO.TLD2040 AND TLD2024 R  
WITH 1/4-28 THREADED SHANKS.

- 1 1/2" SHAFT TRAVEL.
- .001 INCREMENT DEPTH ADJUSTMENT.
- BALL BEARING DEPTH STOP.
- 1/4-28 FEMALE THREADED SHAFT.
- POSITIVE LOCK ADJUSTMENT.
- 1/4" HEX SHANK
- FULL BALL BEARING CONSTRUCTION
- RATED AT 10,000 R.P.M.

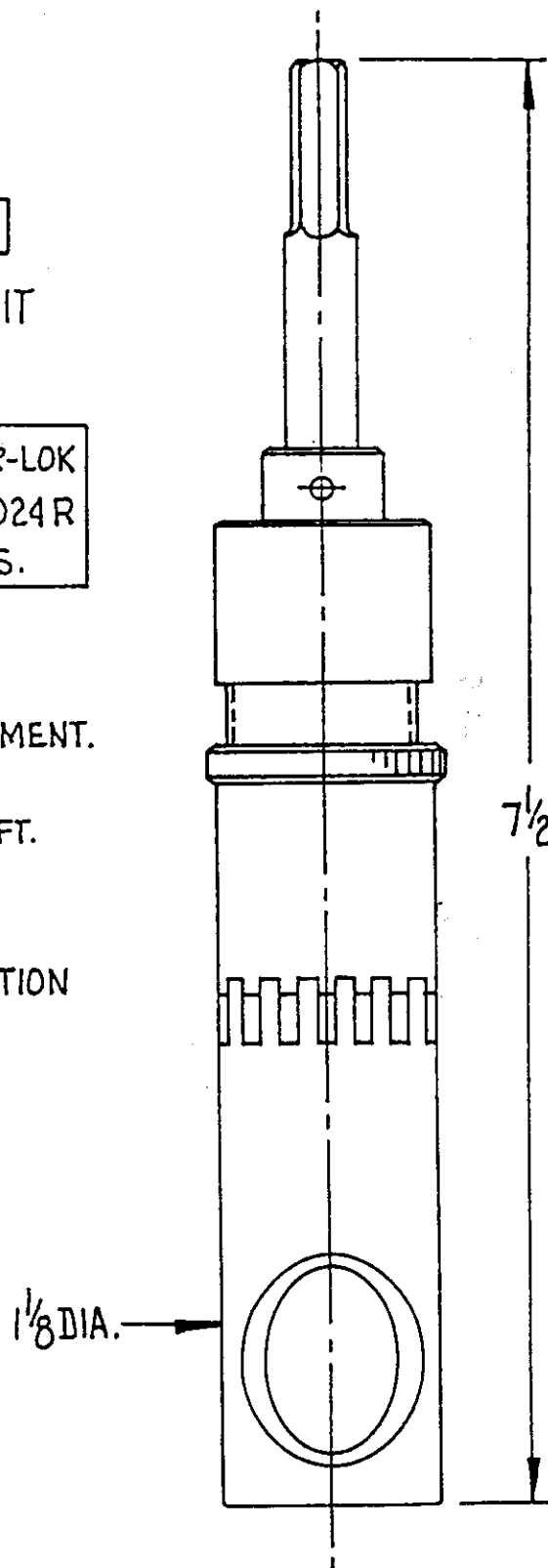

A  
21



MAGNAVON INDUSTRIES

HEAVY DUTY SERIES

MICRO STOP COUNTERSINK UNIT  
NO.1150

DESIGNED TO ACCOMODATE TAPER-LOK  
CUTTERS NO.TLD 2040 AND TLD 2040R  
WITH 7/16-20 THREADED SHANKS.

- 2 1/4 SHAFT TRAVEL.
- .001 INCREMENT DEPTH ADJUSTMENT.
- BALL BEARING DEPTH STOP.
- 7/16-20 FEMALE THREADED SHAFT.
- POSITIVE LOCK ADJUSTMENT.
- 3/8 DIA. SHANK WITH THREE FLATS.
- RATED AT 2000 R.P.M.

1 1/2 DIA.

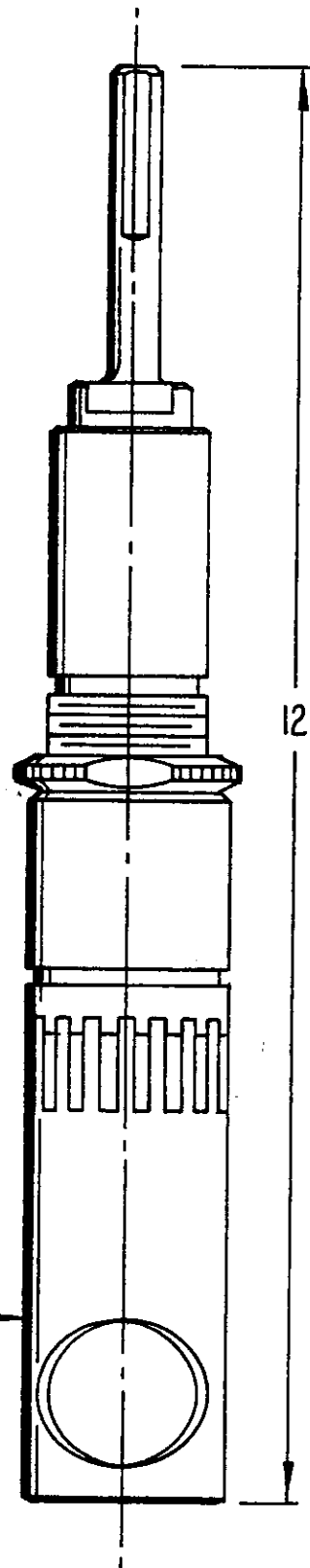

A  
22



MAGNAVON INDUSTRIES

HEAVY DUTY SERIES

MICRO STOP COUNTERSINK UNITS

NO.1180 - HAS 1" - 14 THREADED SHAFT

NO.1194 - HAS 5/8" - 18 THREADED SHAFT

DESIGNED TO ACCOMODATE TAPER-LOK  
CUTTERS NO.TLD 2024 AND TLD 2024 R  
SERIES.

- 3" SHAFT TRAVEL.
- .001 INCREMENT DEPTH ADJUSTMENT.
- BALL BEARING DEPTH STOP.
- POSITIVE LOCK ADJUSTMENT.
- 3/4 DIA. SHANK WITH THREE FLATS.
- RATED AT 2000 R.P.M.

2 1/2 DIA.

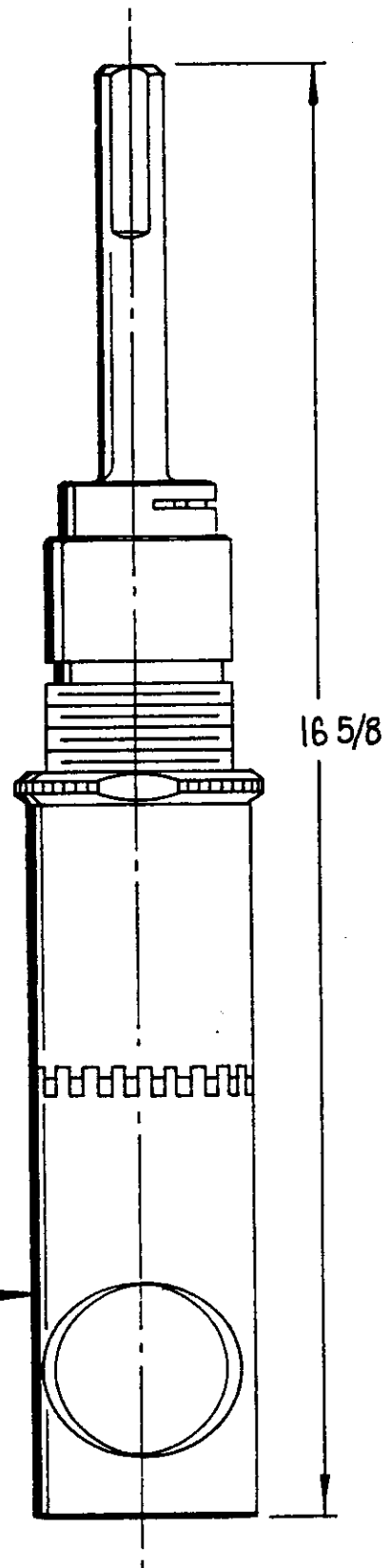

A  
23





# MAGNAVON INDUSTRIES

BASIC PART NUMBER	BODY DIA.
1034-6	3/8
1034-7	7/16
1034-8	1/2
1034-10	5/8

AVAILABLE IN THESE PILOT HOLE DIA'S.

.086	.078	.094	.125
------	------	------	------

TO ORDER - SPECIFY BASIC PART NO., PILOT HOLE DIA. AND ANGLE.

EXAMPLE: NO. 1034-8-086-100°

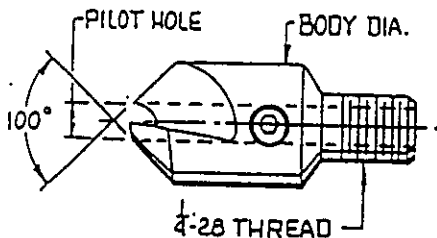

1034 SERIES COUNTERSINK CUTTERS

### 1035 SERIES PILOTS FOR COUNTERSINK CUTTERS

SHANK DIA.	PILOT DIA. RANGE
.077	.077 - .128
.085	.085 - .128
.093	.093 - .192
.124	.124 - .312
.1865	.1865 - .375
.249	.249 - .625

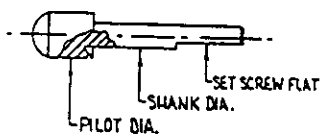

REF. PILOT DIA. MUST BE .002 UNDER HOLE DIA. IN WORKPIECE.

EXAMPLE TO ORDER:

1035-124-310

PILOT DIA.  
SHANK DIA.  
BASIC NO.

BASIC PART NUMBER	BODY DIA.
1134-6	3/8
1134-7	7/16
1134-8	1/2
1134-10	5/8

TO ORDER - SPECIFY BASIC PART NO., PILOT DIA. AND ANGLE.

EXAMPLE: NO. 1134-7-096-100°

\*PILOT DIA. MUST BE .002 UNDER DRILLED HOLE DIA.

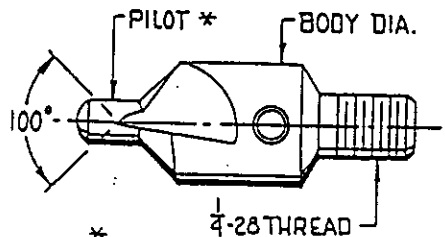

1134 SERIES COUNTERSINK CUTTERS

BASIC PART NUMBER	BODY DIA.
1164-12	3/4
1164-14	7/8
1164-16	1
1164-18	1 1/8
1164-20	1 1/4
1164-22	1 3/8

NOTE:

TO ORDER - SPECIFY BASIC PART NO., PILOT DIA. AND ANGLE.

EXAMPLE:

NO. 1164-14-498-100°

\*PILOT DIA. IN THOUSANDTHS

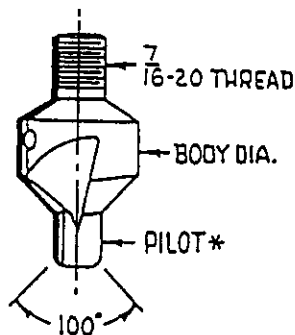

1164 SERIES COUNTERSINK CUTTERS



# MAGNAVON INDUSTRIES

## COUNTERSINK CUTTER - 3 FLUTE

BASIC NO.	BODY DIA.
2301-12	3/4
2301-14	7/8
2301-16	1
2301-18	1 1/8

EXAMPLE TO ORDER:

2301-14-.1875-100°

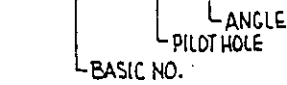

PILOT HOLE DIA'S.	.125	.1875	.250
-------------------	------	-------	------

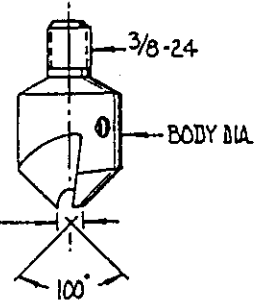

## COUNTERSINK CUTTER - 3 FLUTE

BASIC NO.	BODY DIA.
2302-12	3/4
2302-14	7/8
2302-16	1
2302-18	1 1/8
2302-20	1 1/4
2302-22	1 3/8

EXAMPLE TO ORDER:

2302-20-.250-100°

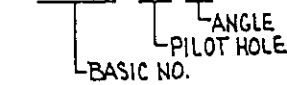

PILOT HOLE DIA'S.	.1875	.250	.3125
-------------------	-------	------	-------

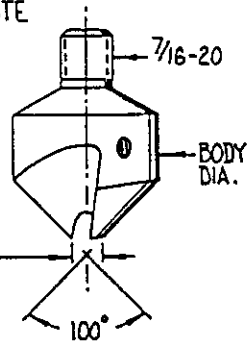

## HOLE RADIUS CUTTER - NO. 2303 SERIES

EXAMPLE TO ORDER:

2303-3/8-24-7/8-.030-.248

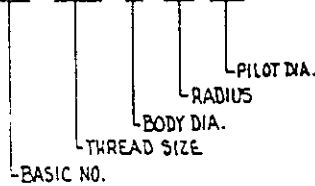

THREAD SIZE	1/4-28	3/8-24	7/16-20
-------------	--------	--------	---------

BODY DIA'S	3/8 THRU 1/2
------------	--------------

RADIUS	.005 THRU .090
--------	----------------

PILOT DIA'S	.098 THRU .750
-------------	----------------

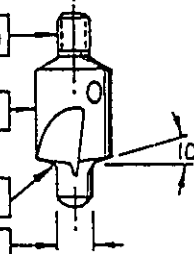

PART NO.	D	A	FASTENER SIZE REF.	THREAD	TYPE REF.
1297-1/8	.365	.124	1/8	1/4-28	HI SHEAR
- 5/32	.365	.157	5/32		
- 3/16	.438	.1875	3/16		
- 1/4	.500	.247	1/4		
- 5/16	.562	.310	5/16		
- 3/8	.625	.373	3/8		
- 7/16	.750	.434	7/16		
- 1/2	.875	.497	1/2		
- 9/16	.937	.558	9/16	3/8-24	HUCK
- 5/8	1.000	.620	5/8		
1297-L6	.323	.1875	L6 LOCK BOLT		
- L8	.413	.250	L8 LOCK BOLT		
- OS8	.372	.265	OS8 BLIND RIVET	1/4-28	HUCK
- L10	.528	.3125	L10 LOCK BOLT		
- OS10	.465	.339	OS10 BLIND RIVET		
- L12	.622	.375	L12 LOCK BOLT		
- OS12	.550	.397	OS12 BLIND RIVET		

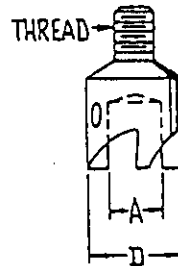

1297 SERIES  
HOLLOW CUTTERS  
[FOR COLLAR REMOVAL]

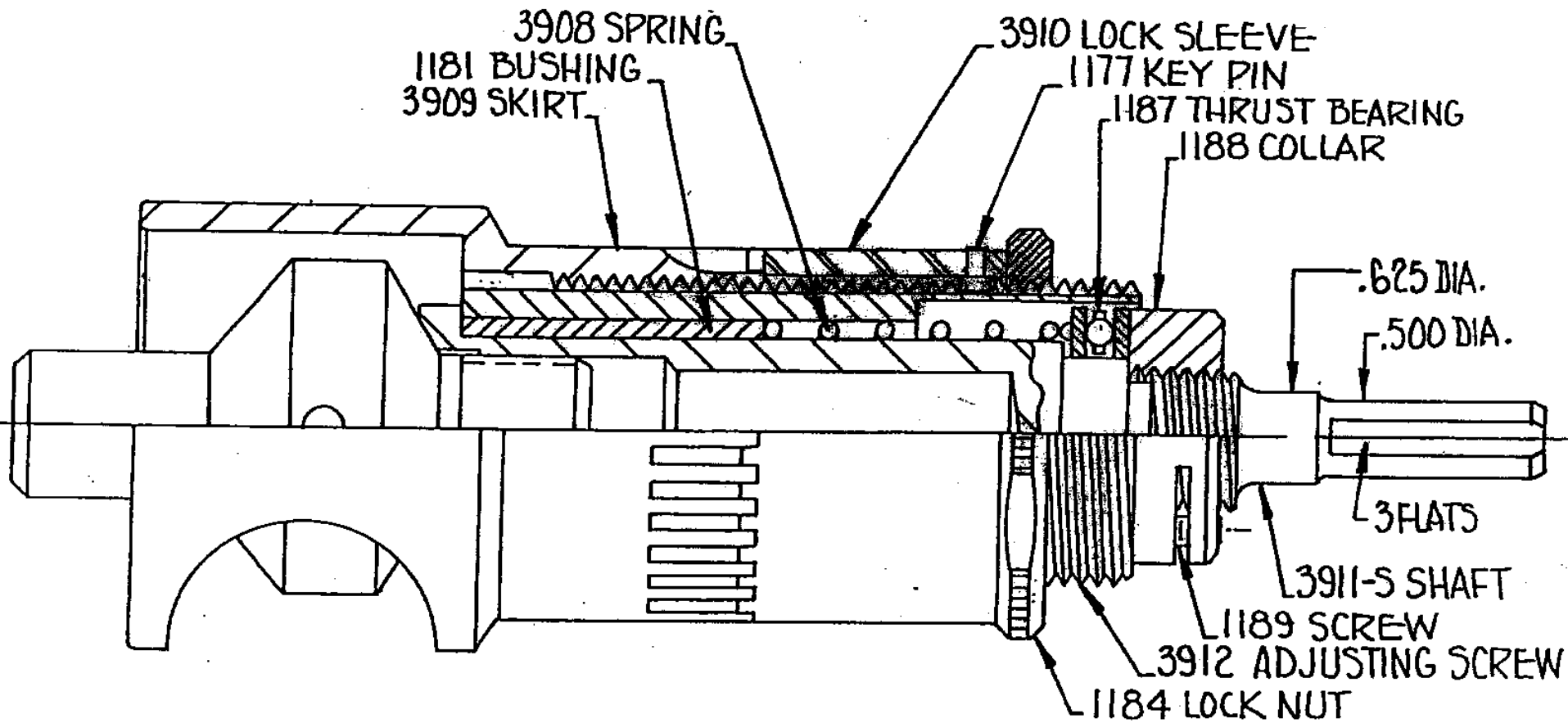

REF:

1. SKIRT O.D. 3.0
2. CUTTER O.D. 2.25
3. SPINDLE THD 1.0-14
4. ADJUSTMENT .002 PER. TOOTH
5. STROKE 1.0

MAGNAVON

MICRO-STOP UNIT

3878-S